

# ELECTRO-MECHANICAL XL-SERIES RECIPROCATOR

Mitsuba Electro-Mechanical Reciprocator possesses the capability to vary the speed & stroke as desired with a simple touch screen control.

The Reciprocator is electrically driven via an AC geared motor, giving gentle and distinct motion thus ensuring the best possible coating result.

The movement of the carriage is controlled by a most upto date AC frequency drive and advanced digital controller to achieve the desired stroke and speed. The control panel incorporates a user friendly touch screen for extreme simplicity of operations even by unskilled labour.

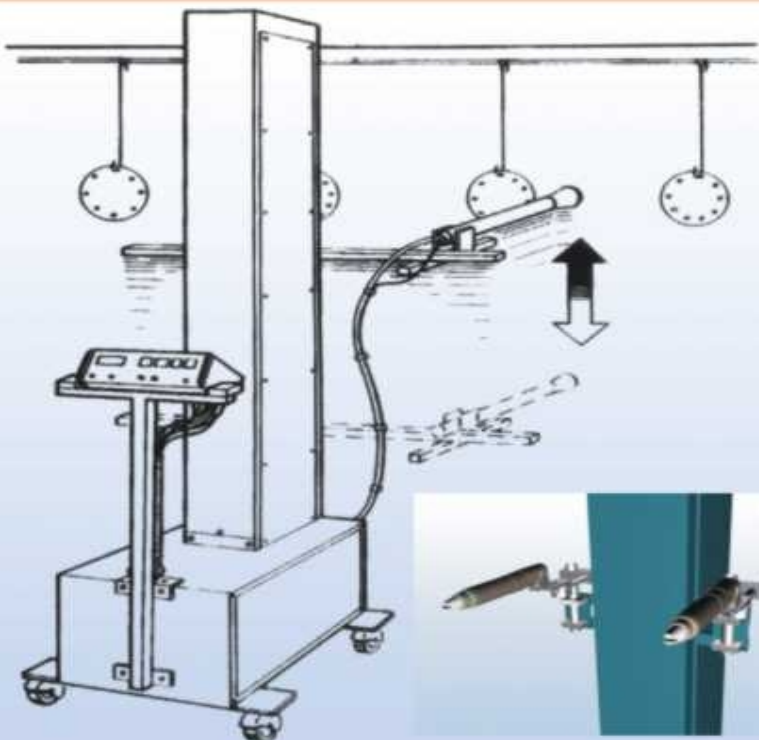

1. Increased Simplicity -  
Advanced touch screen digital control.
2. Maximum Reliability + Ease -  
Simplicity of design. The screen itself guides the user on what to touch so no formal usage training is needed.
3. Improved Finish -  
Smooth movement during traversing and change of direction.
4. Quick Job Change -  
Pre-programmable preset points for automatic selection of stroke and speed.

## PART LIST

1. STROKE CARRIAGE
2. GUIDE WAYS
3. COUNTERBALANCE CARRIAGE
4. GEAR MOTOR
5. ROLLER CHAIN
6. SECOND ROLLER CHAIN
7. SPROCKET
8. PANEL STAND
9. GUN
10. SQUARE PILLAR
11. RECIPROCATOR BASE
12. CASTOR WHEELS

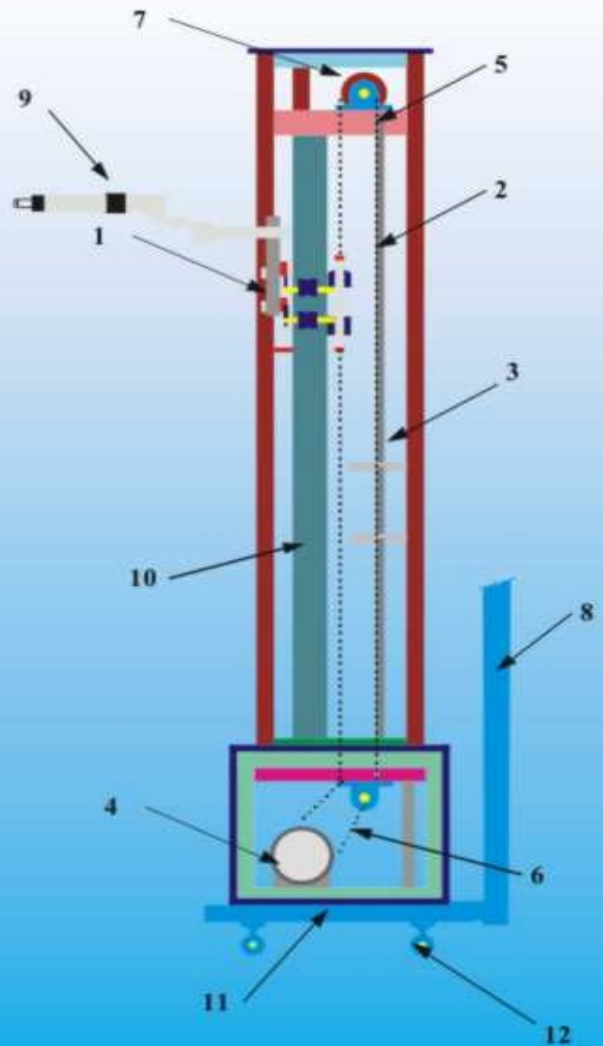

## Touch screen control



## SPECIFICATIONS

- ☞ Speed : 0-30 Mt./Min (Infinitely Selectable)
- ☞ Minimum Stroke : 100 mm
- ☞ Standard Stroke Length : 1200 mm, 1500 mm, 1800 mm, 2000 mm, 2500 mm.

## CONTROL

**Analog :** Operator sets both speed and stroke separately for each type of job.

**Digital :** New Touch screen Graphic Display & control.

- ☞ Pre-Set Points : Any speed & stroke selectable, ninety nine (99) Pre-Set programmable points.
- ☞ Multi Speed : Three multi speed settings selectable along the main stroke. Speed can be different in various lengths of the same stroke.
- ☞ Can be integrated with "SPRAY POLICE" powder optimisation hardware, so gun spray is triggered only during presence of work piece.

**mitsuba**  
SYSTEMS (I) P. LTD.

34/H, Laxmi Industrial Estate, New Link Road, Andheri (W), Mumbai - 400 053. India  
Tel: +91 22 2631 8633/ 6692 4151-52-53 Fax: +91 22 6692 4154.  
Email: mitsuba@vsnl.com Website: <http://www.powdergun.com>