

AUTOMATIC POWDER SPRAY SYSTEM

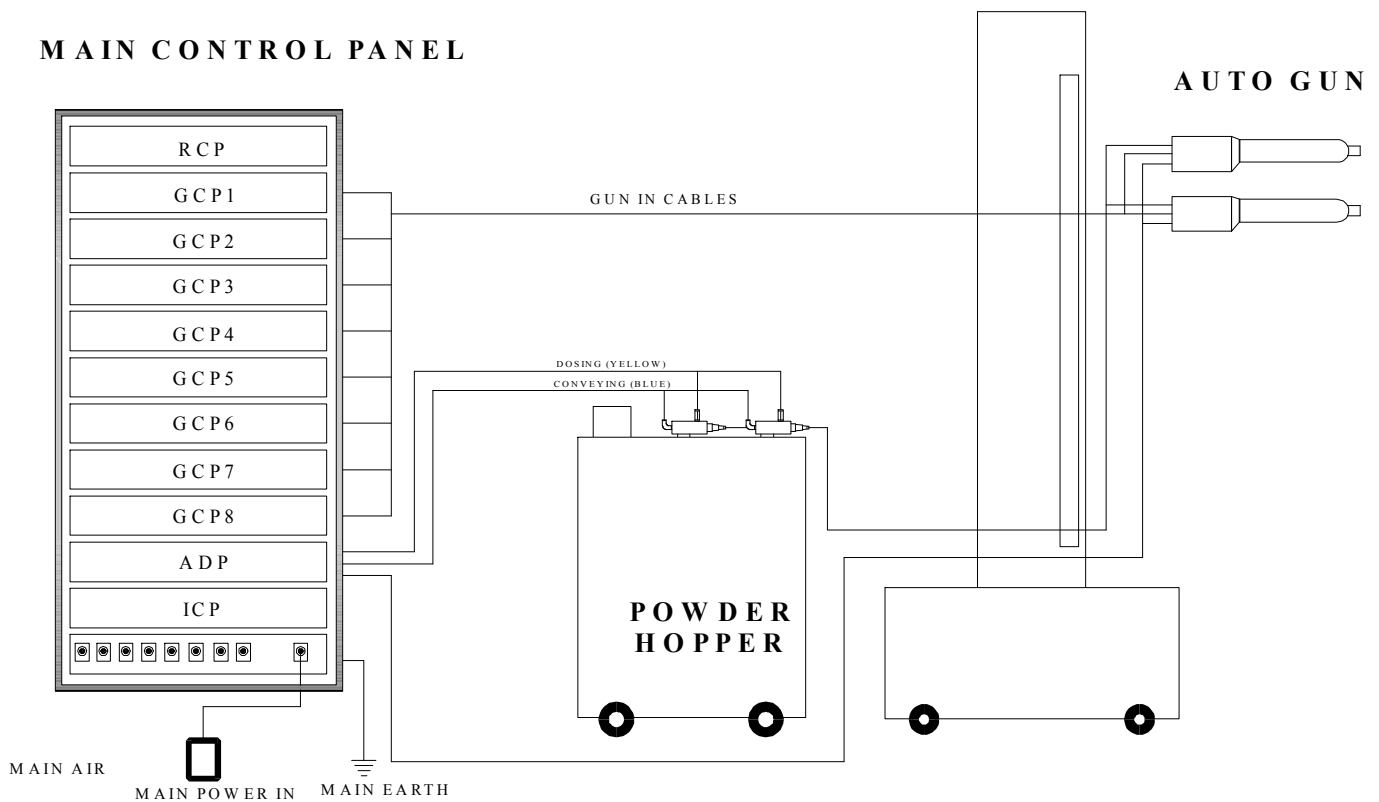

34/H Laxmi Industrial Estate, New Link Road, Andheri (W), Bombay-400053. India
Phone : ++91 22 66924151-52-53 Fax : ++91 22 6692 4154
Email : mitsuba@vsnl.com Web Page : <http://www.powdergun.com>

PRIMARY DATA

The ***MITSUBA SYSTEMS*** Automatic Powder Coating System with the Automatic Infiniti™ Powder Spray Guns is specially designed to meet the demands of production line applications in both manufacturing, and custom electrostatic coating applications.

The Flexible, Modular structure of the ***MITSUBA SYSTEMS*** Automatic Powder Coating System is readily adaptable to any changes in your installation.

The ***MITSUBA SYSTEMS*** Automatic Powder Coating System grows with your needs and can be easily expanded to incorporate more gun systems as and when required. The various standard Master Control Panels can be cascade interlocked with each other.

The components shown in the detailed scope of supply vary as per the number of gun systems offered.

AUTOMATIC PLANT WITH RECIPROCATOR

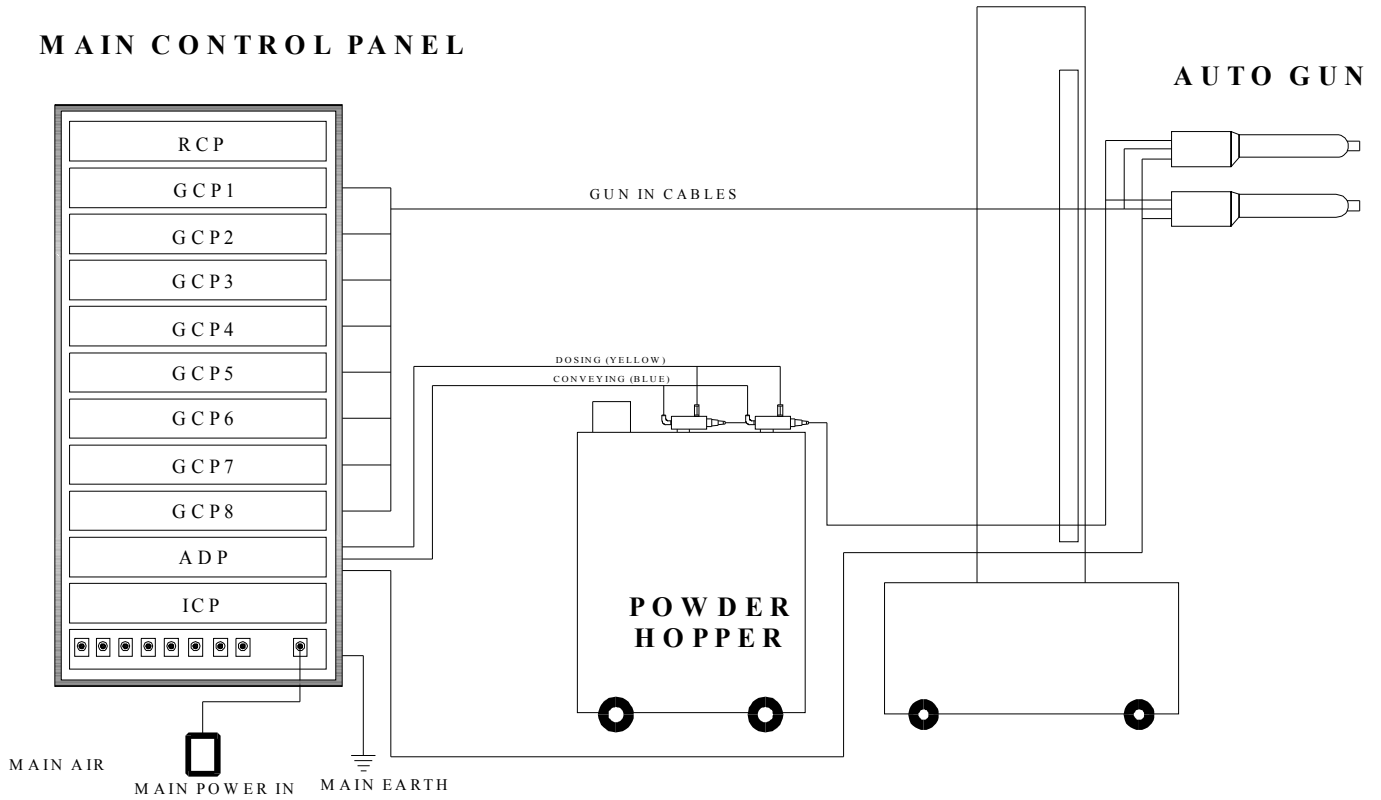

AUTOMATIC PLANT WITHOUT RECIPROCATOR

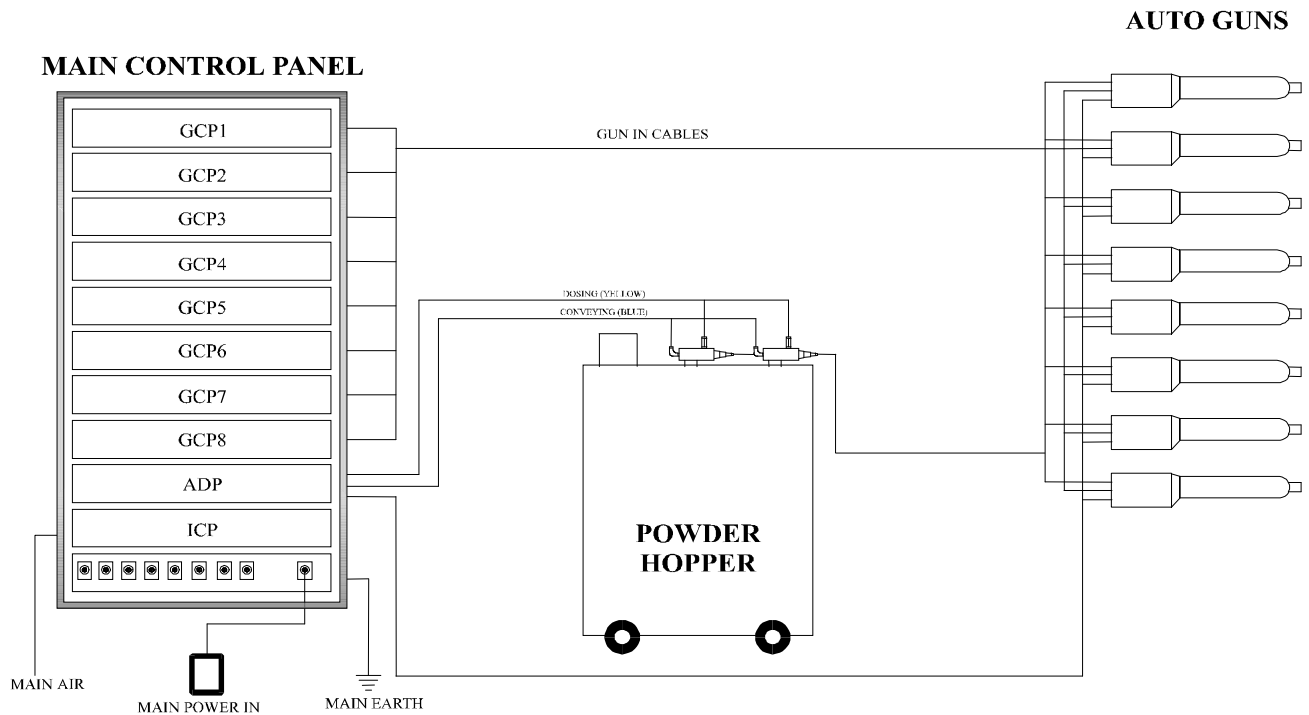

SCOPE OF SUPPLY

A typical **MITSUBA SYSTEMS** Automatic Powder Coating System Plant is built with a modular concept and comprises of :

<u>ITEM</u>	<u>Page #</u>	
Master Control Panel (MCP) (Rack Cabinet) [standard upto 8 guns]	05	
Air Distribution Panel (ADP) [standard upto 8 guns]	11	
Interlocking Control Panel (ICP) [standard upto 8 guns]	14	
<ul style="list-style-type: none">• Individual Gun Control Panels (GCP)• Integrated 100 kv Infiniti TM Automatic Carona Guns• High Performance Powder Pumps• Automatic Tribo Gun with various Spray Heads (optional)	07 18 21] Qty.of Gun systems as specified
<ul style="list-style-type: none">• Centralized Powder Hopper [Kg. sizes as specified]	21	
<ul style="list-style-type: none">• Necessary Interconnecting Cables & Accessories		

MASTER CONTROL PANEL

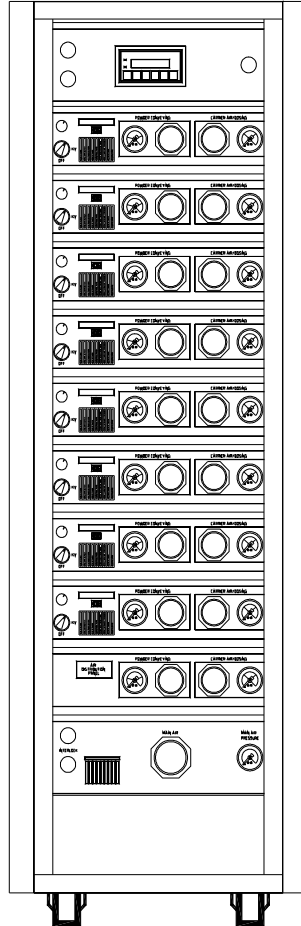

34/H Laxmi Industrial Estate, New Link Road, Andheri (W), Bombay-400053. India

Phone : ++91 22 66924151-52-53

Fax : ++91 22 6692 4154

Email : mitsuba@vsnl.com

Web Page : <http://www.powdergun.com>

MASTER CONTROL PANEL

This consists of a standard modular enclosure system consisting of side & rear panels, top cover (vented if desired), internal AC distribution panel, earthing distributor & frontal panel mounting for easy access to controls. All incoming & outgoing wires are connected on terminals. All wires & cables are introduced from the bottom. This MCP houses

1. Individual Gun Control Panels (GCP)
2. Air Distribution Panels (ADP)
3. Interlocking Control Panel (ICP)
4. Reciprocator Control Panel (RCP) [in case of Reciprocator systems]

The mechanical structure, the components for the front panels & the mounting conditions confirm strictly to international standards. These features permit reliable & long lasting protection in harsh & adverse environments

OPTIONAL

- * IP 55 protection rating to provide complete protection against ingress of dust & water jets from all directions is optional & can be provided.
- * A thermal management system for cooling/ventilation may be required in certain rare cases & can be provided if desired even in IP 55 protected enclosures.
- * Eye hooks are provided for ease in transport movement.

TECHNICAL DATA

Dimensions	: Ht 1440 mm W 600 mm D 600 mm
Input voltage	: Single Phase 110/120/220/230/240V, 50 / 60 Hz OR Three Phase 380 / 440 V 50 / 60 Hz
Power Consumption	: Max. 1250W [with reciprocator controls]
Input Air Pressure	: 8 kg/cm ²
Air Connection	: ¾" BSP
Air Consumption	: 5 m ³ / hr per Gun
Max. Water content permitted	: 1.3 g
Max. Oil content permitted	: 0.1 ppm
Safety Class	: IP 50 (IP 55 is optional)

GUN CONTROL PANEL

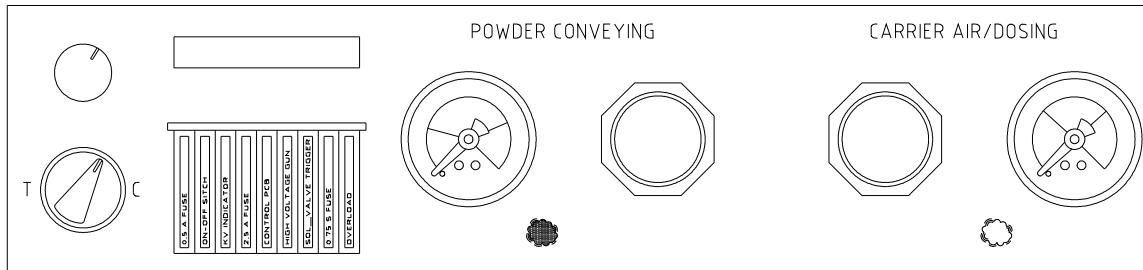

34/H Laxmi Industrial Estate, New Link Road, Andheri (W), Bombay-400053. India

Phone : ++91 22 66924151-52-53

Fax : ++91 22 6692 4154

Email : mitsuba@vsnl.com

Web Page : <http://www.powdergun.com>

GUN CONTROL PANEL (GCP)

The GCP is a standard control panel which is individual for all powder guns & can be operated for both the Corona & Tribo gun.

Each panel houses the electrical, electronics & pneumatics which control the individual guns. The voltage at the gun tip, the powder flow & cloud pattern are controlled through the GCP.

All wiring is undertaken through a motherboard. All components are only plugged into the motherboard. Complex interconnecting wires & circuit tracing is completely eliminated. In case of a fault, extremely fast trouble shooting is possible the motherboard system permits instant change.

An ultra modern and advanced, automatic diagnostic “Smart Tracker” system monitors and indicates the performance of every component. This eliminates the need for complex circuit tracing in case of any error troubleshooting is easiest with the “Smart Tracker”.

TECHNICAL DATA

Dimensions	: Ht 88 mm W 450 mm D 270 mm
Control Elements	: ON/OFF Switch Potentiometric HV Control up to 100 KV Digital indicator for 100 KV o/p Conveying air control regulator with gauge Dosing air control regulator with gauge
Control Signals	: HV indicator Micro Amp Read out Disturbance Acknowledgement

GUN CONTROL PANEL (GCP)

PNEUMATIC DATA

Maximum input pressure	7 bar
Optimum input pressure	6 bar
Maximum water vapour content in compressed air	1.3 g ³
Maximum oil vapour content in compressed air	0.1 ppm
Maximum Compressed air consumption	11 m ³ / hr.

ELECTRICAL DATA

Single phase AC current, selectable voltages	220V or 230/110V
Frequency	50 / 60 Hz.
Connected loads	60VA
Safety class	IP 54 (P43)
Temperature Range	-2 °C to 50 °C
Nominal Input Voltage	10 V eff.
Output Voltage	100 KVDC -ve (+ve on request)
Nominal Output Current	100 micro amps.

GUN CONTROL PANEL (GCP)

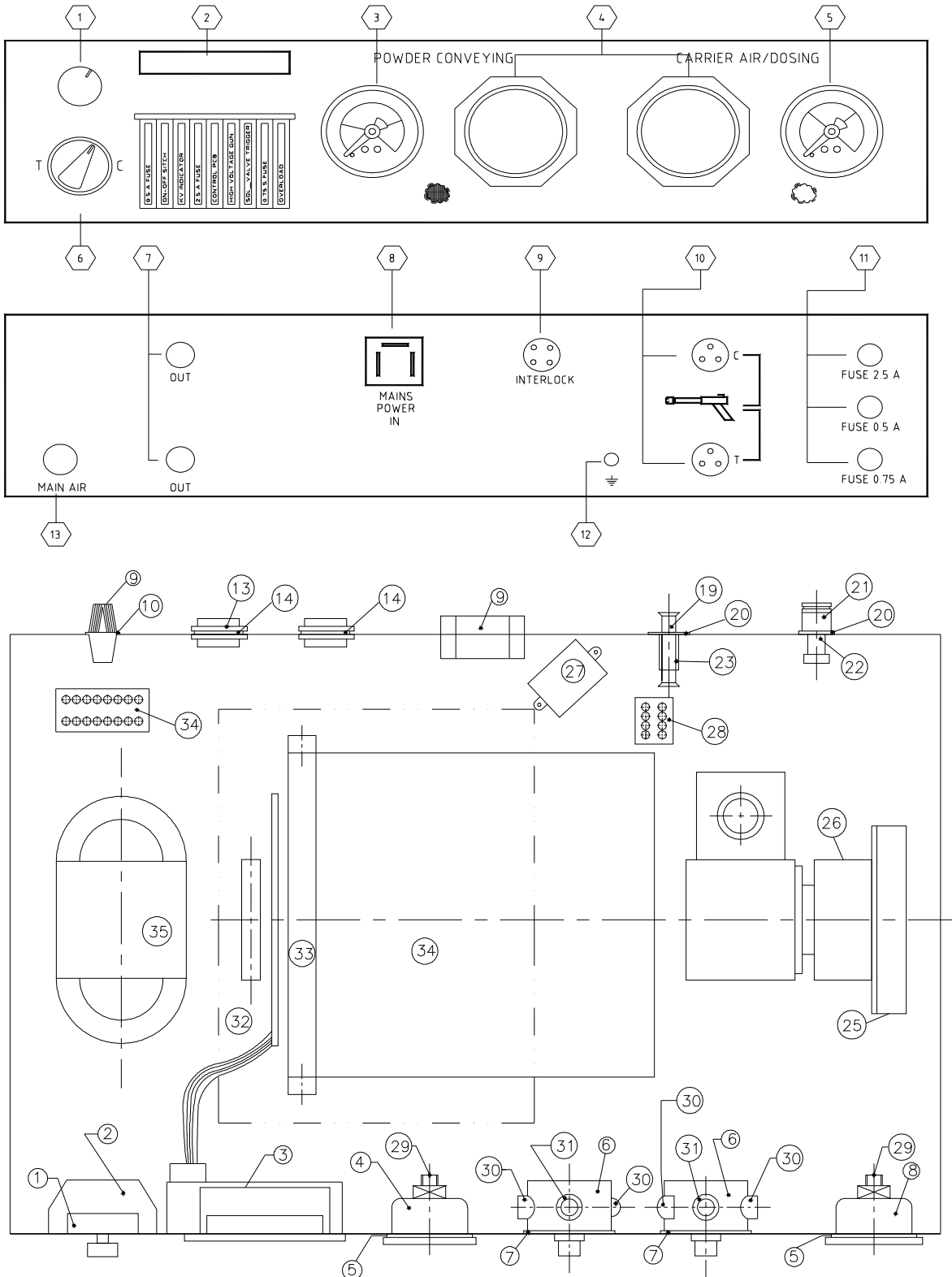

AIR DISTRIBUTION PANEL

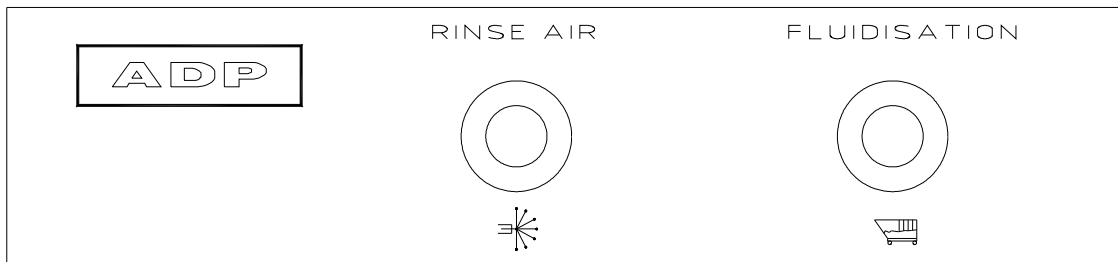

34/H Laxmi Industrial Estate, New Link Road, Andheri (W), Bombay-400053. India

Phone : ++91 22 66924151-52-53

Fax : ++91 22 6692 4154

Email : mitsuba@vsnl.com

Web Page : <http://www.powdergun.com>

AIR DISTRIBUTION PANEL (ADP)

The Air distribution panel consists of regulators and gauges. The ADP houses both the fluidization regulator with gauge & electrode rinsing regulator with gauge.

The ADP also houses the Main air distribution manifold. This aids in uniform distribution of main air supply to the Gun Control Panels.

TECHNICAL DATA

- Dimensions** : Ht 88 mm
W 450 mm
D 270 mm
- Control Elements** : Fluidization Air pressure control with Gauge
Electrodes/Deflectors rinsing Air pressure control with Gauge
- Control Signals** : Release of Rinsing air at gun tip
Release of air for fluidization

PNEUMATIC DATA

- Input pressure max. 7 kg/cm²
Max. Water content permitted 1.3gms/m³
Max. Oil content permitted 0.1ppm

AIR DISTRIBUTION PANEL (ADP)

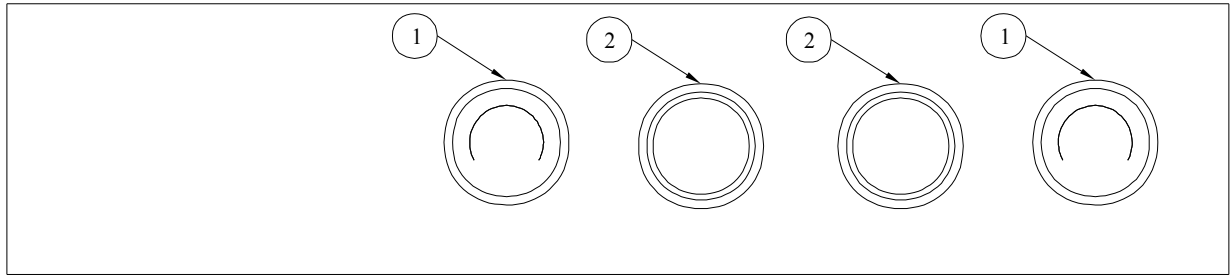

A.D.P. FRONT

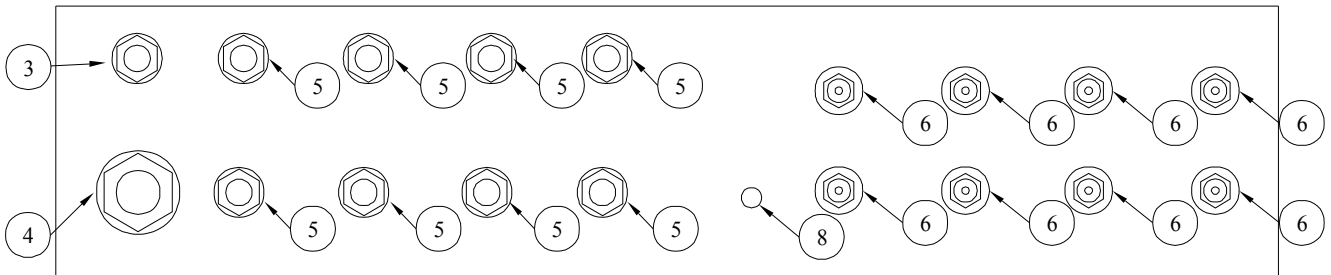

A.D.P. BACK

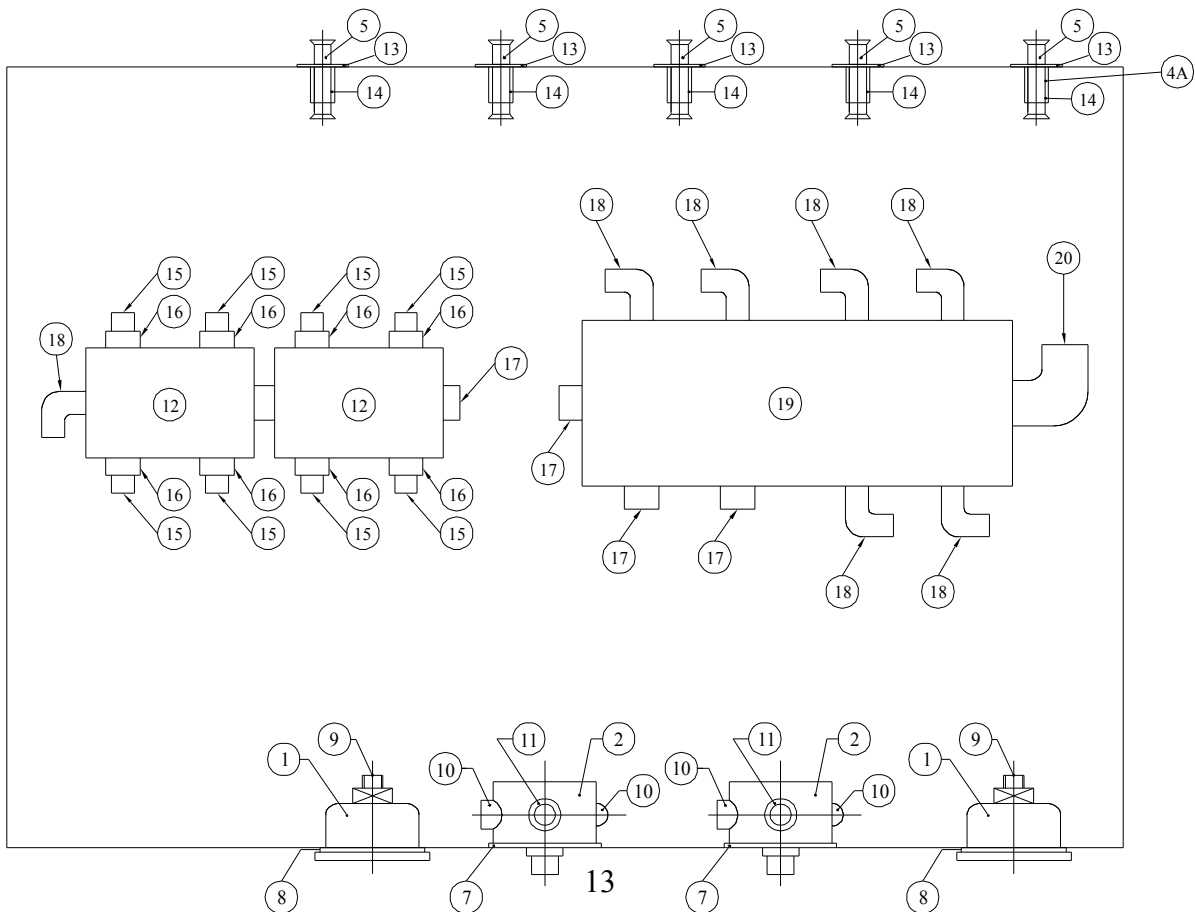

INTERLOCKING CONTROL PANEL

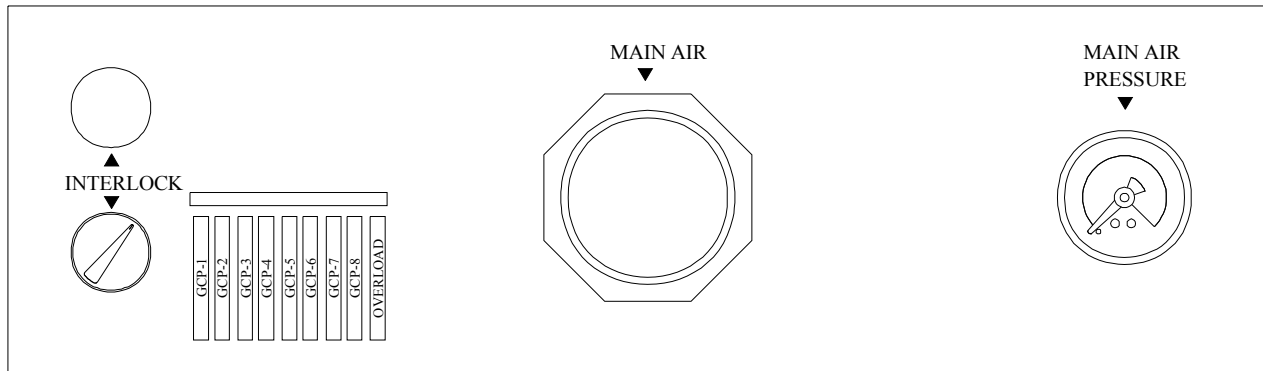

INTER LOCKING CONTROL PANEL (ICP)

This is a panel mainly used for interlocking Individual Gun Controls with each other and with the External related systems of the Powder coating plant such as Conveyor, Reciprocator, Recovery plant motors etc.

It also consists of a Main Air Distribution Control regulator which distributes the compressed air from the Main line to the Gun Control Panels (GCP's) Hopper & Guns.

The ICP is interlocked with individual GCP's such that if one GCP trips on overload conditions then all the individual Gun HV shall be switched off. Simultaneously a volt free contact is given allowing for tripping of Conveyor/Reciprocator/Recovery motors etc if so desired.

Vice versa if any of the Conveyor/Reciprocator/Recovery Motors trip due to any condition, the ICP does not allow the Individuals Gun HV to be switched on. This Interlock is also accepted in the form of volt free contacts from the above systems.

Emergency STOP is cross connected to all Emergency STOP's at plant.

TECHNICAL DATA

Dimensions : Ht 132 mm
W 450 mm
D 270 mm

Control Elements : 1. Main Switch with Indicator to Switch on Individual GCP's.
2. Interlocking with individual GCP for O/L Trips.
3. Interlocking with Conveyor, Reciprocator, Recovery plant motors etc.
4. Input air control valve with gauge

Control Signals : System ON
Emergency STOP
Automatic Operation ON
Reciprocator OK
Conveyor OK
Recovery OK
Release of compressed air for GCP's

INTER LOCKING CONTROL PANEL (ICP)

ELECTRICAL DATA

220 V Single Phase
each potential free contact 220 V, 2A max.

INPUTS (Volt free contacts)

Emergency STOP
CONVEYOR OK
RECIPROCATOR OK
RECOVERY OK

OUTPUTS (Volt free contacts)

Emergency STOP
GUN SYSTEM TRIPPED

INTER LOCKING CONTROL PANEL (ICP)

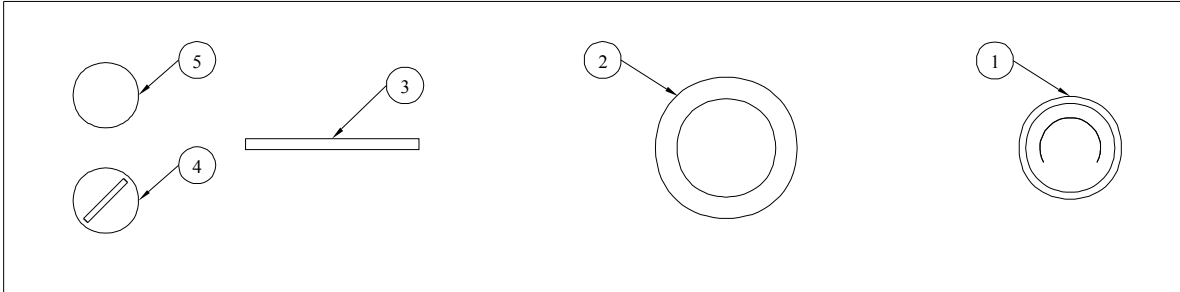

FRONT VIEW

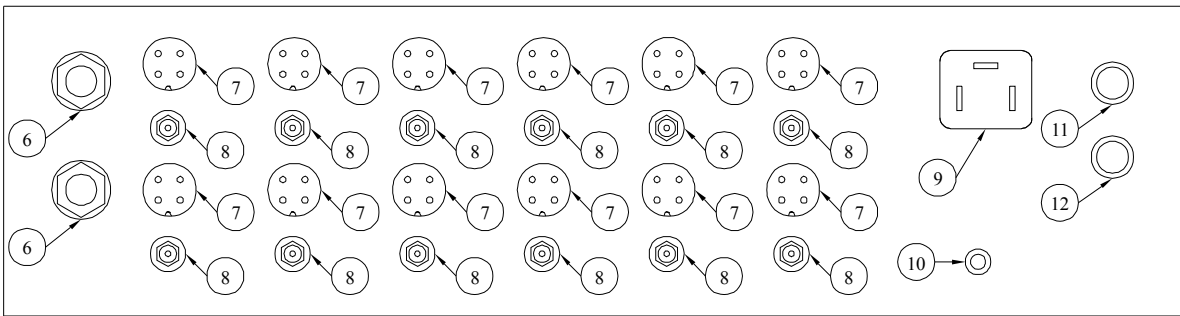

BACK VIEW

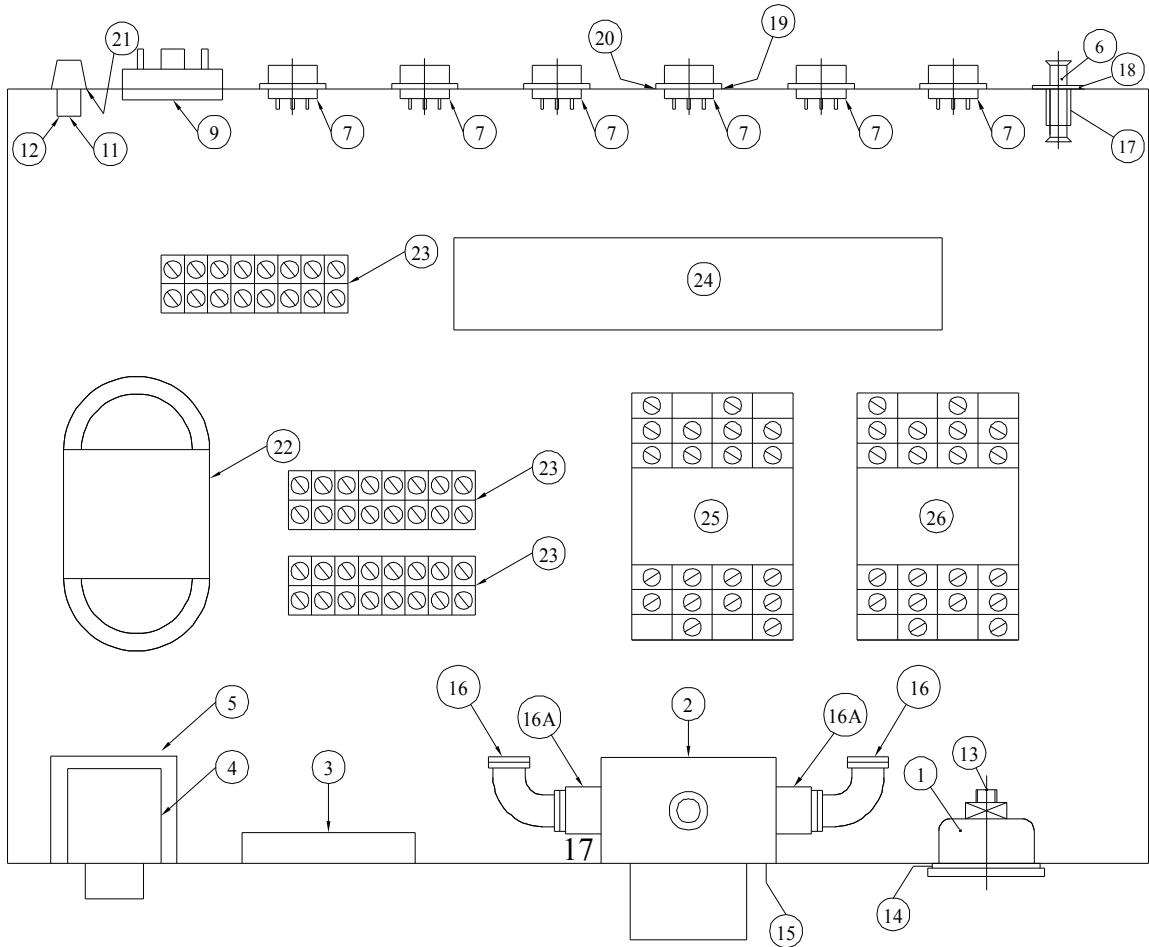

**INFINITI™ AUTOMATIC
ELECTROSTATIC CARONA GUN**

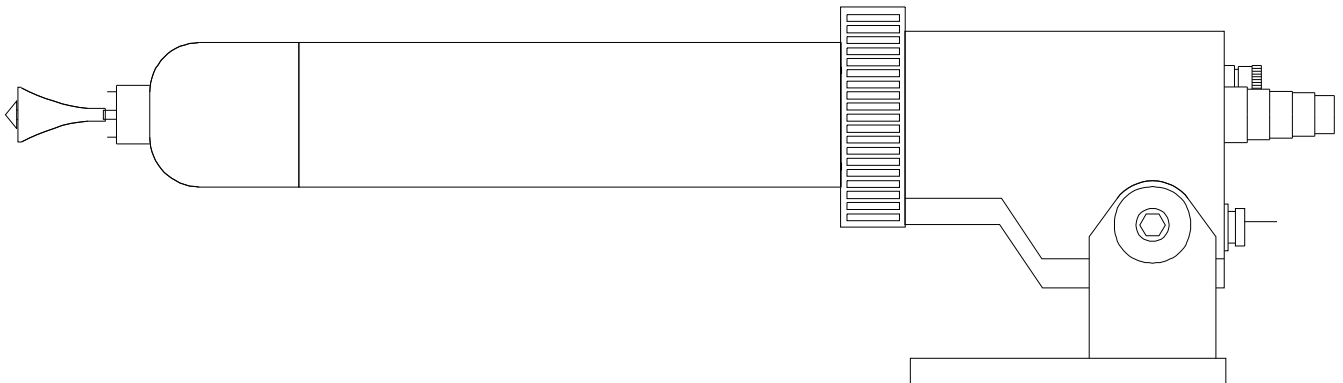

34/H Laxmi Industrial Estate, New Link Road, Andheri (W), Bombay-400053. India

Phone : ++91 22 2631 8633 / 2633 4735

Fax : ++91 22 6692 4154

Email : mitsuba@vsnl.com

Web Page : <http://www.powdergun.com>

AUTOMATIC INTEGRATED ELECTROSTATIC GUN

The Automatic Powder Spray Guns have the 100KV generator in the gun itself. They include an air rinsing system to continuously clean the electrodes / deflectors.

Without this feature after spraying for a while the electrodes get coated with a layer of insulating powder and hence deposition efficiency drops. In manual systems, this layer can be wiped away or air cleaned very easily.

However in an Automatic system it is inconvenient to consistently pay attention to this and therefore an additional air line which passes through the gun, continuously rinses the electrodes so optimum transfer efficiency is continuously maintained as insulating powder does not accumulate over the electrodes.

The Automatic Powder Spray Guns are provided with the necessary low voltage cables and powder hoses - 10 meters length for each gun.

TECHNICAL DATA

EXTERNAL PNEUMATIC DATA

Maximum input pressure	7 bar
Optimum input pressure	6 bar
Maximum water vapour permitted in compressed air	1.3 g / m ³
Maximum oil vapour permitted in compressed air	0.1 ppm
Maximum Compressed air consumption	8 m ³ / hr (For Powder Flow) 3 m ³ / hr (For Rinsing)

ELECTRICAL DATA

Nominal Input Voltage	10 V eff.
Output Voltage	100 KVDC -ve (+ve on request)
Nominal Output Current	100 micro amps.

OTHER DATA

Gun Weight	Approx. 750 gms
Gun Length	Approx. 330 mm.

AUTOMATIC INTEGRATED ELECTROSTATIC GUN

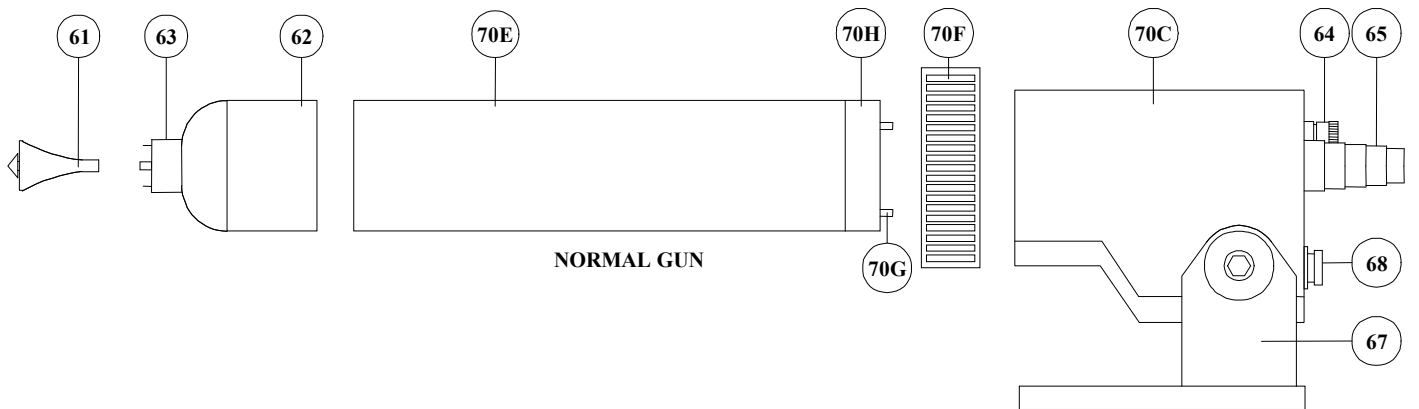

CENTRALIZED POWDER HOPPER

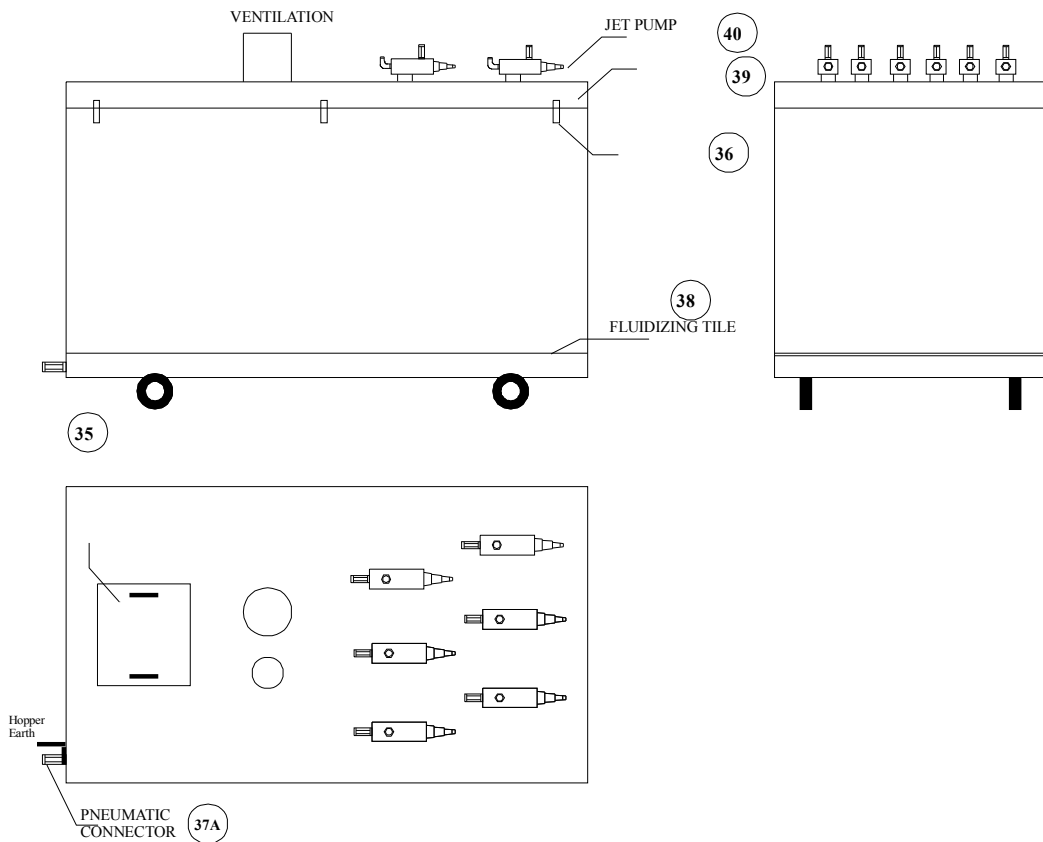

34/H Laxmi Industrial Estate, New Link Road, Andheri (W), Bombay-400053. India

Phone : ++91 22 66924151-52-53

Fax : ++91 22 6692 4154

Email : mitsuba@vsnl.com

Web Page : <http://www.powdergun.com>

**CENTRALIZED POWDER HOPPER
WITH HIGH PERFORMANCE POWDER PUMPS**

This 200 Kgs. Stainless Steel powder hopper is of a fluidization type and having the possibility to remove the porous tile for the cleaning as well as access door to pour powder without disturbing the spraying operation. The powder pumps are mounted on the hopper lid and are manufactured from aluminium and have separate inputs for conveying and dosing air. All pneumatic fittings are of quick disconnect type. The most important characteristic is the ventury design which enables a surge free powder spraying as the dosing air is fed after the suction area.

The concentration of powder-air mixture can be perfectly controlled as the dosing and conveying air controls are individually separate. The max. powder output per pump is 30Kgs./hr.

TECHNICAL DATA

Dimensions : 980mm x 480mm x 800mm.--- 200 kgs
750mm x 480mm x 480mm.--- 100 kgs

OTHER DATA

Capacity : 200 Kgs (Other Capacities as Specified)

Air Requirements : Fluidizing - max 20 zxm³ / hr.

No. of Pumps : As Specified.

Powder pump output. : 0 to 30 Kgs / hr. controllable